

2170 SOUTH 3140 WEST  
WEST VALLEY CITY, UTAH 84119

PHONE: (801) 908-5456  
E-MAIL: info@fpti.org

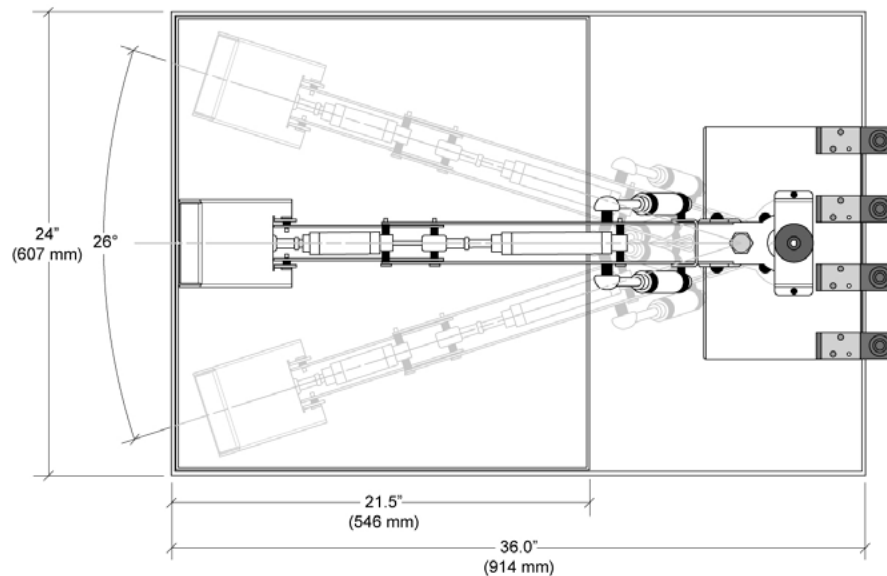

SPECIFICATIONS:

*Cylinders* - Dual lift Stroke: 2" (51mm)  
Bucket rollback Stroke: 2" (51mm)  
Boom/Stick Stroke: 3" (76mm)

*Pressure gauge* - 0 to 200 PSI (0 to 13.8 bar)

*Working area* - 24" (610mm) x 36" (914mm)

*Water pump* - 1.6 GPM (6 Lpm)  
115 VAC  
0.8 amps (1.7 max.)  
160 PSI (11 bar)  
Intermittent duty cycle

*Material and finish* - Powder-coated steel

*Directional control valves* - Qty. 4

*Water tank* - Size = 2-3/4" (70mm) x 2" (51mm) x 2" (51mm)  
Volume = 0.05 gallons (0.18 liters)

ADDITIONAL ITEMS:

- Detailed assembly instructions and parts list.
- All fittings, spacers, bolts, nuts, etc. required for assembly and operation.
- 50' (15.24m) x 1/4" (6.35mm) clear plastic tubing.
- Divider tray for holding material for lifting.
- 3-lbs (1.36kgs) of lifting materials.
- Highly durable ABS acrylic tray liner.